

1W High Sensitivity Wireless Transceiver Module

Product Specification

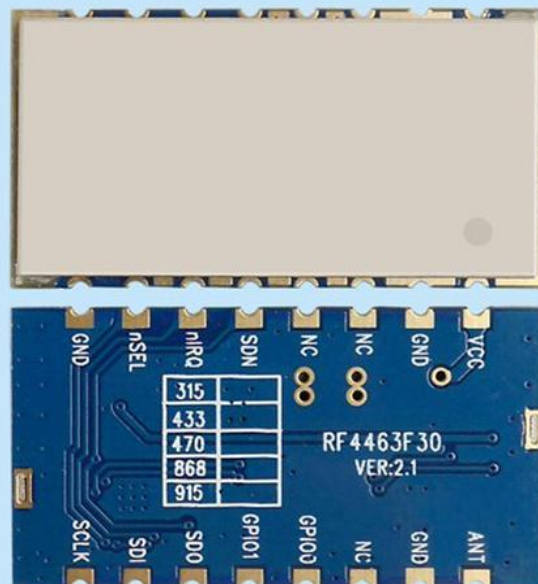

Catalog

1. Description.....	- 3 -
2. Features.....	- 3 -
3. Application.....	- 3 -
4. Block Diagram.....	- 4 -
5. Electrical Specifications.....	- 4 -
6. Schematic.....	- 6 -
7. Pinout:.....	- 5 -
8. Antenna.....	- 6 -
9. Mechanism dimensions(Unit: mm).....	- 7 -
10. Products Ordering Information.....	- 7 -
Appendix:	- 8 -

Note: Revision History

Revision	Date	Comment
V1.0	2015-10-16	First release
V2.0	2016-8-5	Updated layout
V2.1	2017-06	Logo updated
V2.2	2018-12-15	Update the PIN photo

1. Description

RF4463F30 is 1W RF module embedded with amplifier and LNA circuit. High quality of component, tightened inspection and long term test make this module reliable for long time, long distance communication in varies environment. RF4463F30 adopts Silicon Lab si4463 RF chip, which is a highly integrated wireless ISM band transceiver (EzradioPro2). The features of high sensitivity (-126 dBm), +30 dBm output power, 10PPM crystal, and good RF matching circuit make this module work well in hot/cold environment with reliable communication and long distance.

RF4463F30 is manufactured and tested strictly using lead-free process and complies with RoHS and Reach standards.

2. Features

- Frequency Range: 315/433/490/868/915
(Customizable 142-1050 MHz)
- Sensitivity up to -126 dBm
- Maximum output power: +30dBm
- 10mA@receiver status
- Data transfer rate: 0.1-1000 Kbps
- (G)FSK,4(G)FSK, (G)MSK,OOK and ASK
- 3.3-6.5 V Power supply
- Digital received signal strength indicator (RSSI)
- Timed wake-up function
- The antenna automatically match and two-way switch control
- Configurable packet structure
- Preamble detection
- 64/128byte transmit and receive data register (FiFo)
- Low-power detection
- Temperature sensor and 8-bit analog-to-digital converters
- Operating Temperature Range:-40 ~ + 85 °C
- Integrated voltage regulator
- Frequency hopping
- Power-on reset function
- Built-in crystal adjustment function

3. Application

- Remote control
- Remote meter reading
- Industrial control
- home automation remote sensing
- Individual data records
- sensor network
- tire pressure monitoring
- health monitoring
- wireless PC peripherals
- tag reading and writing

4. Block Diagram

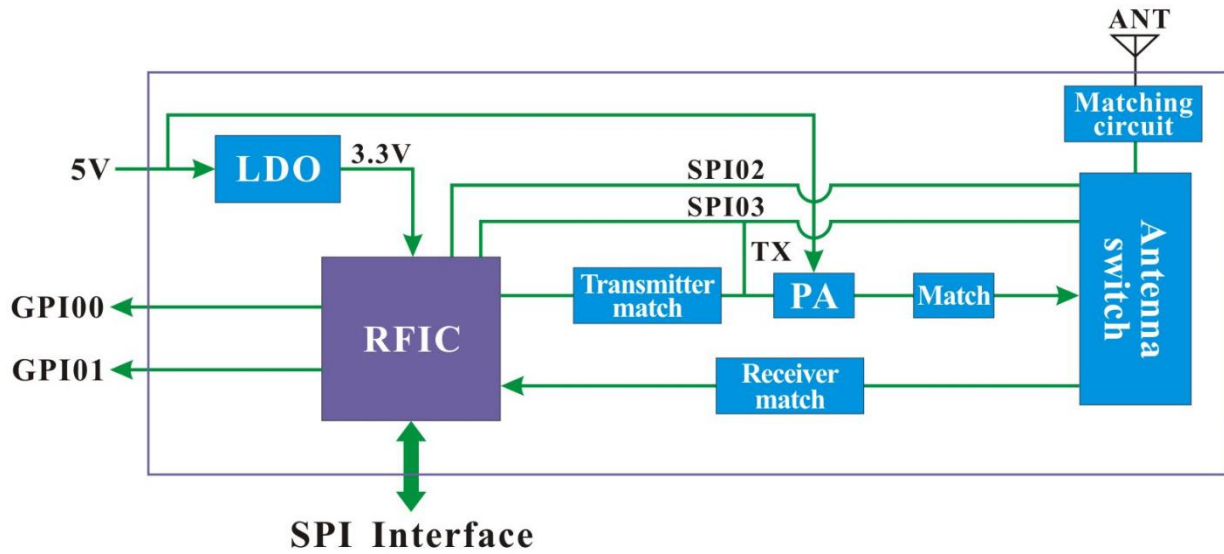

5. Electrical Specifications

★ Note: the following parameters is VCC = 5 v, with 50 ohm copper axis test instrumentation.

Parameter	Min	Typ	Max	Unit	Condition
Working Condition					
Working voltage range	3.3	5	6.5	V	
Temperature voltage	-40		85	°C	
Current Consumption					
Receiving current		13.5		mA	Low sensitivity mode
Receiving current		10		mA	High sensitivity mode
Transmitting current		500	550	mA	VCC=5V, TX=30dBm
Sleep current		<2	3	uA	
Parameter					
Frequency range	410	433	450	MHz	@433MHz
	470	490	510	MHz	@490MHz
	863	868	873	MHz	@868MHz
Modulation rate	0.1		1000	Kbps	FSK
Output power range	29.5	30	31	dBm	433MHz, VCC = 5V
Receiving sensitivity	-125	-126		dBm	433MHz, Data rate=600bps, Fdev=3KHz

6. Pinout:

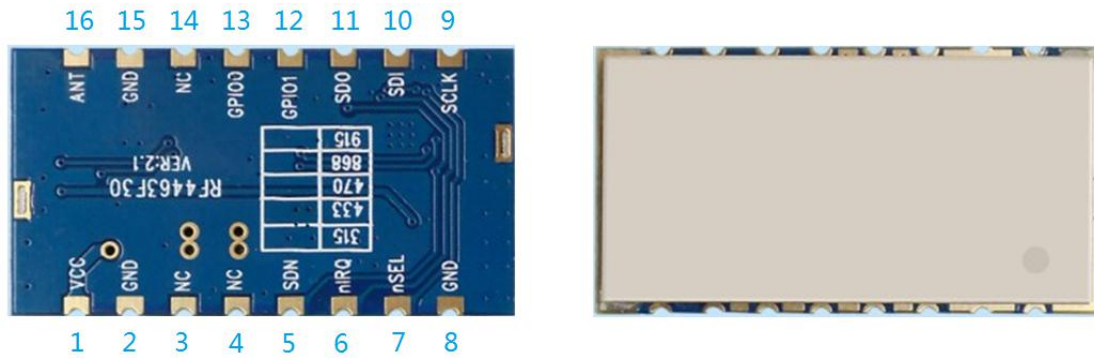

★ The GPIO2, GPIO3 of the Si4463 is connected to the antenna switch on the module.

GPIO2=RX EN; GPIO3=TX EN

Pin NO.	Pin Name	Description
1	VCC	Positive power supply
2	GND	Connected to power ground
3,4,14	NC	Vacant, not connected
5	SDN	Power down control. SDN = 1, power down SDN = 0, normal working
6	nIRQ	Interrupt output
7	nSEL	Serial data selection for SPI interfaces.
8	GND	Connected to power ground
9	SCLK	Serial data clock for SPI interface.
10	SDI	Serial data in for SPI interface.
11	SDO	Serial data out for SPI interface.
12	GPIO1	GPIO1 of Si4463
13	GPIO0	GPIO0 of Si4463 for I/O interface
15	GND	Connected to power ground
16	ANT	From 50 ohm coaxial antenna

★ Note: Pin 15 (ANT GND) is connected to the ground of antenna, do not connect to the ground of power supply. The routing between antenna pad and antenna shall be as short as possible, and thickness larger than 1mm, shown as below:

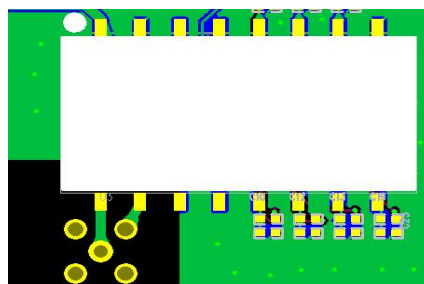

7. Schematic

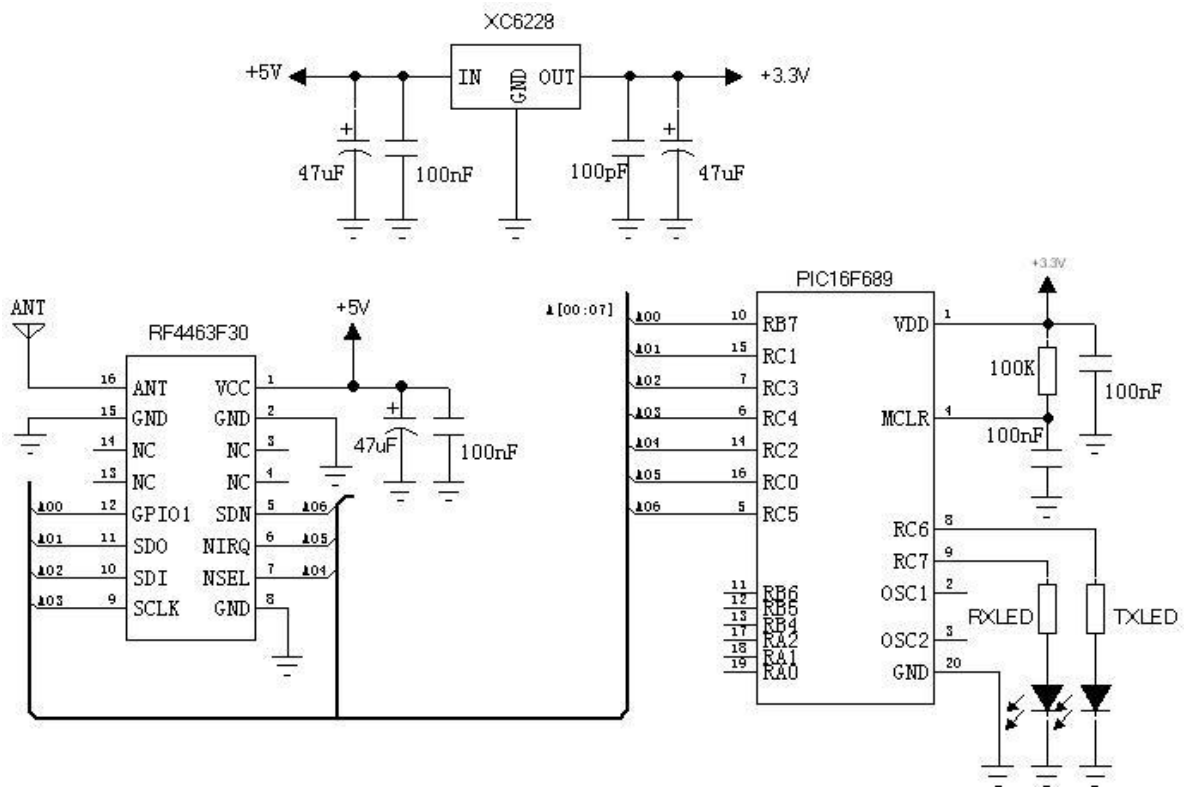

8. Antenna

Antenna is very important for RF communication, its performance will affect the communication directly. Module needs antenna in 50ohm. Common antenna has rubber straight/ elbow/ foldable rod and sucker antenna and etc. Users can order accordingly. To ensure module in the best performance, we suggest to use the our antennas

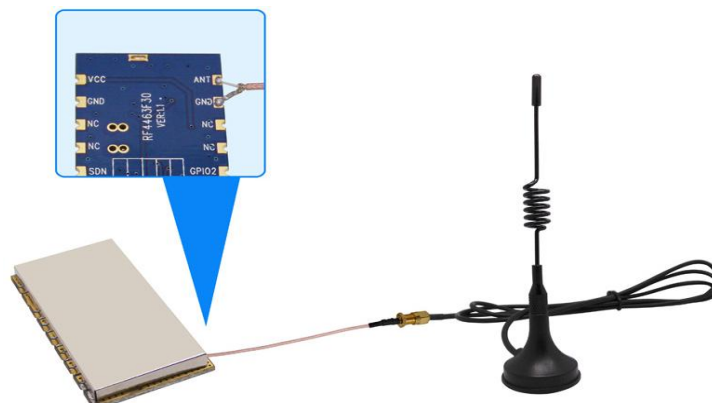

★ To ensure modules get the best performance, user must obey the following principles when using the antennas:

- Put the antenna away from the ground and obstacles as possible as you could;
- If you choose the sucker antenna, pull straight the lead wire as possible as it can be, the sucker under arches should be attached on the metal object.

9. Mechanism dimensions(Unit: mm)

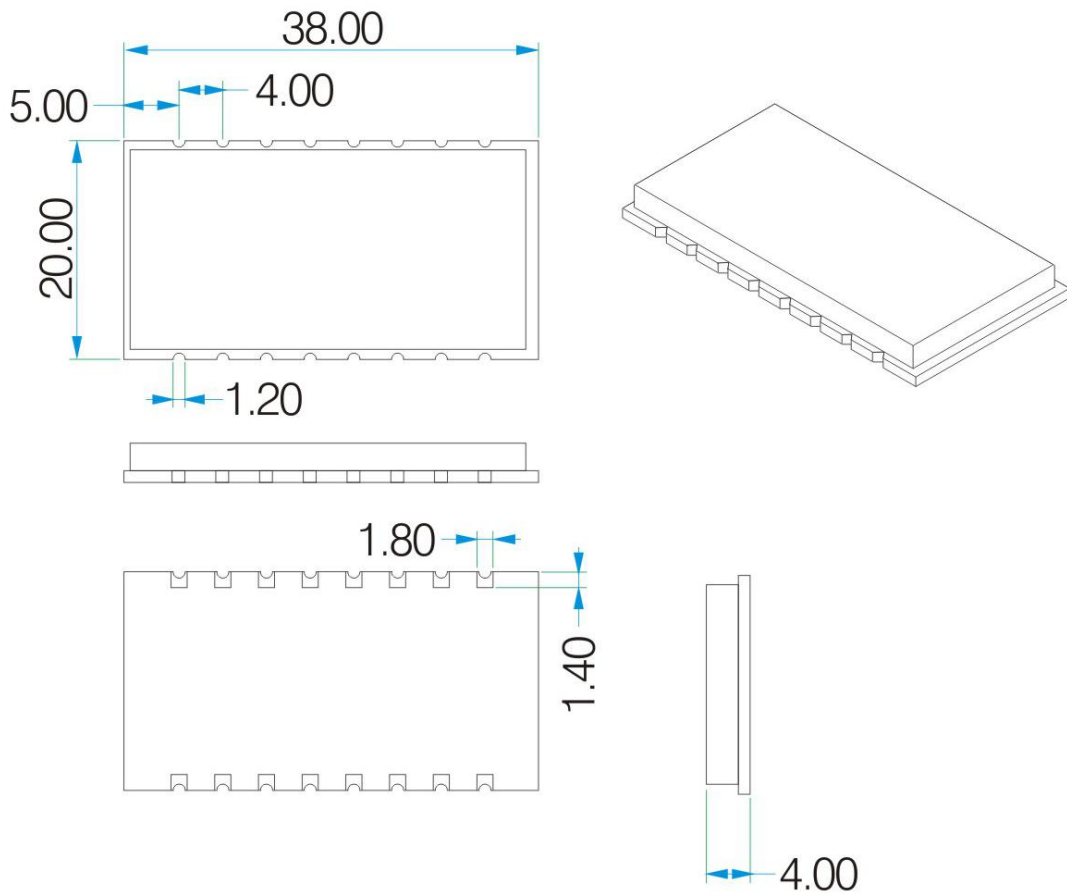

10. Products Ordering Information

RF4463F30-433

Module Model

Frequency

For example: If the customer needs a patch module small crystal 433MHz band module that order model: RF4463F30-433.

Product Name	Description
RF4463F30-150	Working frequency is 150MHz
RF4463F30-433	Working frequency is 433MHz
RF4463F30-490	Working frequency is 490MHz
RF4463F30-868	Working frequency is 868MHz
RF4463F30--915	Working frequency is 915MHz

Appendix:

The module is equipped with a standard DEMO board for customer to debug the program and test distance. It shows as below:



The LCD Full Segment is as below:

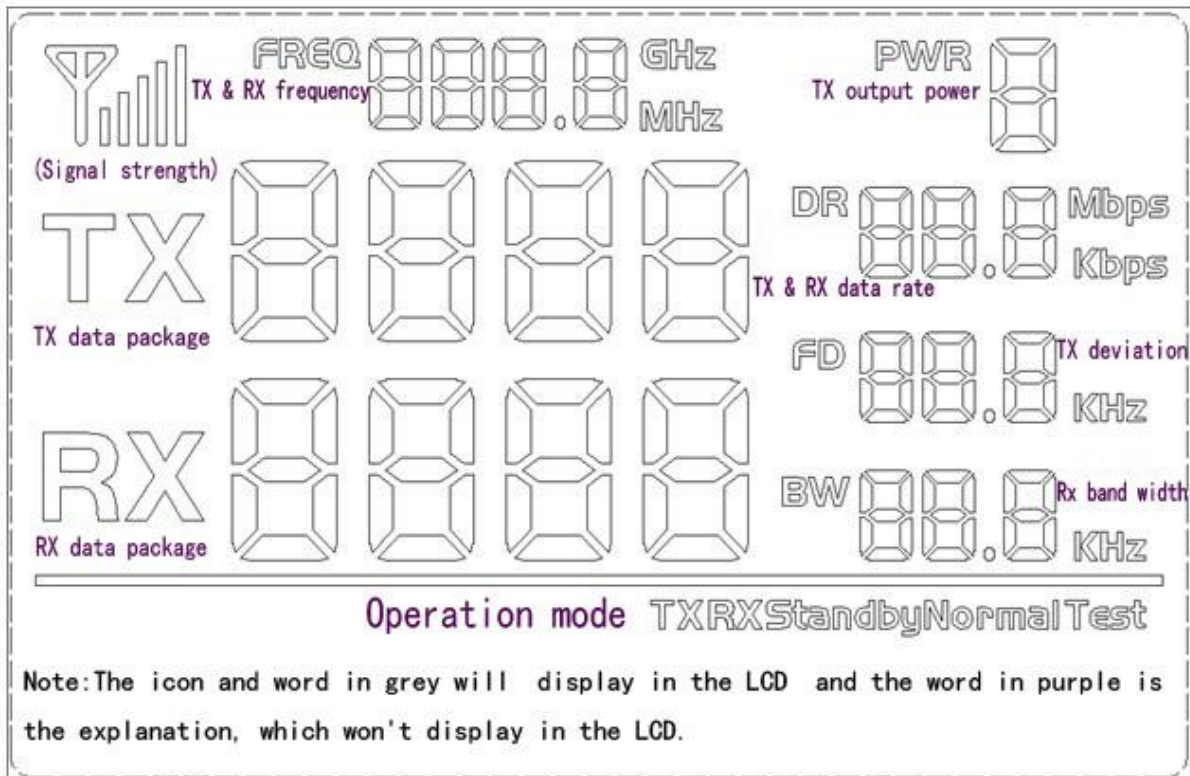

Users can set the parameters of the RF module such as frequency / transmitter power / transmission data rate / working mode through the buttons, and measure the wireless communication distance. Also, all the connection Pins of the module are extended to the demo board, user can use oscilloscope, multi-meter to monitor the operation of the RF module, which is very useful for software programming.

➤ **Working Mode**

There are 5 working modes in the DEMO. They are: Master mode, Slave mode, Tx Test mode, Rx test mode, Standby mode, accordingly, they are displayed on the LCD as: Tx normal / Rx normal / Tx Test / Rx test / Standby. When one packet is transmitted, the Red LED will blink once, the number of Tx packets will increase; when one packet is received, the Blue LED will blink once, the number of Rx packets will increase.

- 1) Master Mode: Send 1 packet per second, and waiting for the acknowledge;
- 2) Slave Mode: Stay in Rx mode to wait for the data from the master, it will send back the acknowledged signal after received the data from the master.
- 3) Tx Test Mode: RF module continuously transmit signal;
- 4) Rx Test Mode: RF module is always in Rx mode;
- 5) Standby Mode: RF module is always in standby state.

➤ **Button Operation**

1) [SET] Button

Press the [SET] button to enter setting mode if not in setting mode. In setting mode, press [SET] button to toggle between the set parameters: frequency /output power / data rate / working mode. The related LCD ICON will flash to indicate.

2) [UP] Button

In setting mode, press the [UP] button to increase the value of flash icon.

3) [Down] Button

In setting mode, press the [Down] button to decrease the value of flash icon.

Note: The DEMO board has FLASH memory inside, all the setting parameters will be saved automatically and keep unchanged even power-off.