

2W High Power Digital Mobile Radio Module

Product Specification

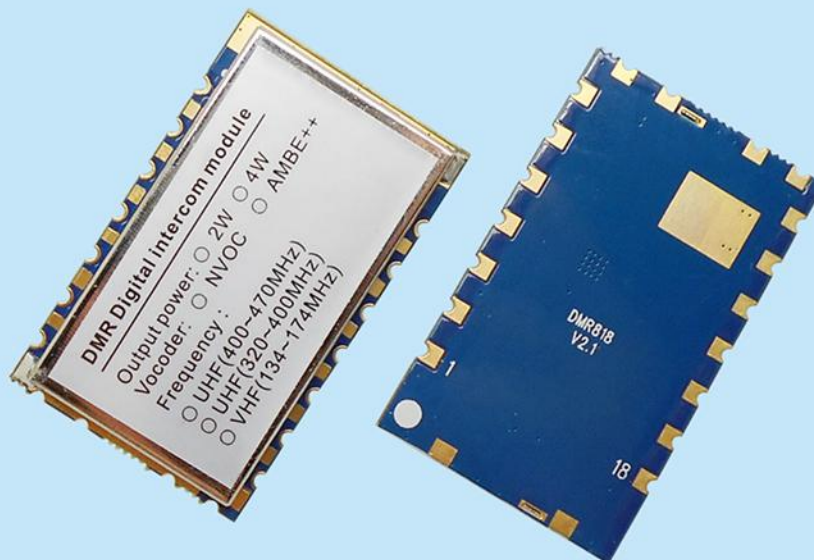

Catalogue

1. Descriptions.....	- 3 -
2. Features.....	- 3 -
3. Application.....	- 4 -
4. Block Diagram.....	- 4 -
5. Electrical Characteristics.....	- 4 -
6. Typical Schematic Circuit:.....	- 5 -
7. Functions descriptions:.....	- 5 -
1) Voice transmission.....	- 5 -
2) Voice receiving.....	- 6 -
3) Messaging.....	- 6 -
4) Switch of Audio amplifier.....	- 6 -
8. Brief of Serial Communication Protocol.....	- 6 -
9. Pin Assignment.....	- 9 -
10. Accessories.....	- 10 -
11. Mechanism Dimension.....	- 11 -
Appendix: SMD Reflow Chart.....	- 11 -

Note: Revision History

Revision	Date	Comment
V1.0	2016-06	First release
V1.1	2016-09	Mechanism Dimension revised
V1.2	2016-12	Mechanism Dimension revised
V1.3	2017-03	Typical Schematic Circuit revised, Bandwidth updated
V1.4	2017-06	Logo updated, modify some description
V1.5	2017-12	Typical Schematic Circuit revised
V1.6	2020-11	Update description

1. Descriptions

DMR818 is a 2W long distance DMR walkie talkie module, it comes with built-in high performance microcontroller, digital mobile radio IC and RF power amplifier. All parameters(CTCSS, CDCSS, SQ, Predefined channels etc.) can be easily modified with protocol. With external power supply, speaker, and audio amplifier, it is easy to become a professional digital walkie talkie. Simplified interface and Ultra small size make this module widely used in various applications and conveniently embedded into various handheld device.

Remark:there are two versions of this module:DMR818-NVOC & DMR818-AMBE.

➤ DMR mode:

- Message transmission and reception.
- Message calling return receipt;
- Enhanced encryption of Voice and Text message.
- Various voice call types: All call, Group call and Private call;
- Reminder for input calling, calling status checking
- Emergency alarm and radio monitor;
- Radio kill and activate;
- Repeater

➤ Analog mode:

- CTCSS/CDCSS configurable
- Squelch levels configurable

2. Features

- UHF band frequency: 400~470 MHz
- VHF band frequency: 134~174 MHz
- 350 band frequency: 320~400 MHz
- Distance up to 5Km
- Max power output to 2W, low power to 0.5W
- High Sensitivity: -124dBm
- Bit error rate down to 1% under -121dBm
- Independent frequency for Tx and Rx.
- 9 adjustable volume
- Analog Bandwidth: 12.5 / 25 KHz
- Digital Bandwidth:6.25KHz
- Message transmission and reception
- DMR(Digital Mobile Radio)/ Analog walkie talkie
- Built-in EEPROM, data saved even powered off
- 1ppm TCXO crystal
- 51 CTCSS
- 166 CDCSS

3. Application

- DMR walkie talkie module
- building security system
- Invisible intercom system
- audio surveillance system

4. Block Diagram

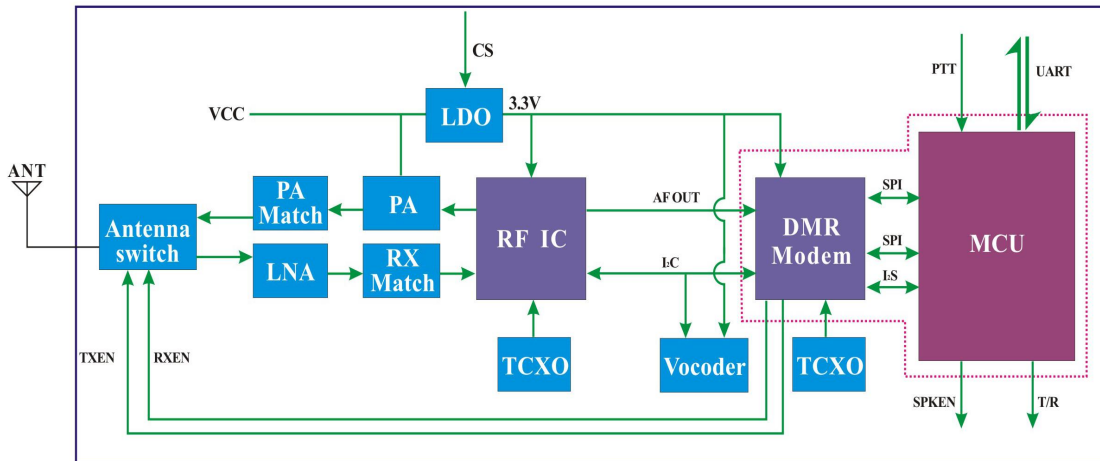

5. Electrical Characteristics

Parameters	Test condition	Min.	Typ.	Max	Unit
Voltage range		3.3	4.2	5.0	V
Operating Temperature		-20	25	60	°C
Frequency range	@UHF	400		470	MHz
	@VHF	134		174	MHz
	@350	320		400	MHz
Start time			100		ms
Uart baud rate			57600		bps
Current Consumption					
Sleep current			< 1		uA
Rx current			50		mA
Tx current (high power)	@VCC=4.0V		800		mA
Tx current (low power)	@VCC=4.0V		400		mA
RF Parameters					
Tx power (high power)	@VCC=4.0V		1.5		W
Tx power (low power)			500		mW
adjacent-channel power	@12.5K offset		-62		dBm
Mic input voltage			0.1	1.6	Vpp
Rx Parameters					
Sensitivity			-124		dBm
Receiving BER(DMR modulation)	@ -121dBm		1		%
Audio output amplitude			1.6	3.0	V
Audio Output impedance			30		KOhm

6. Typical Schematic Circuit:

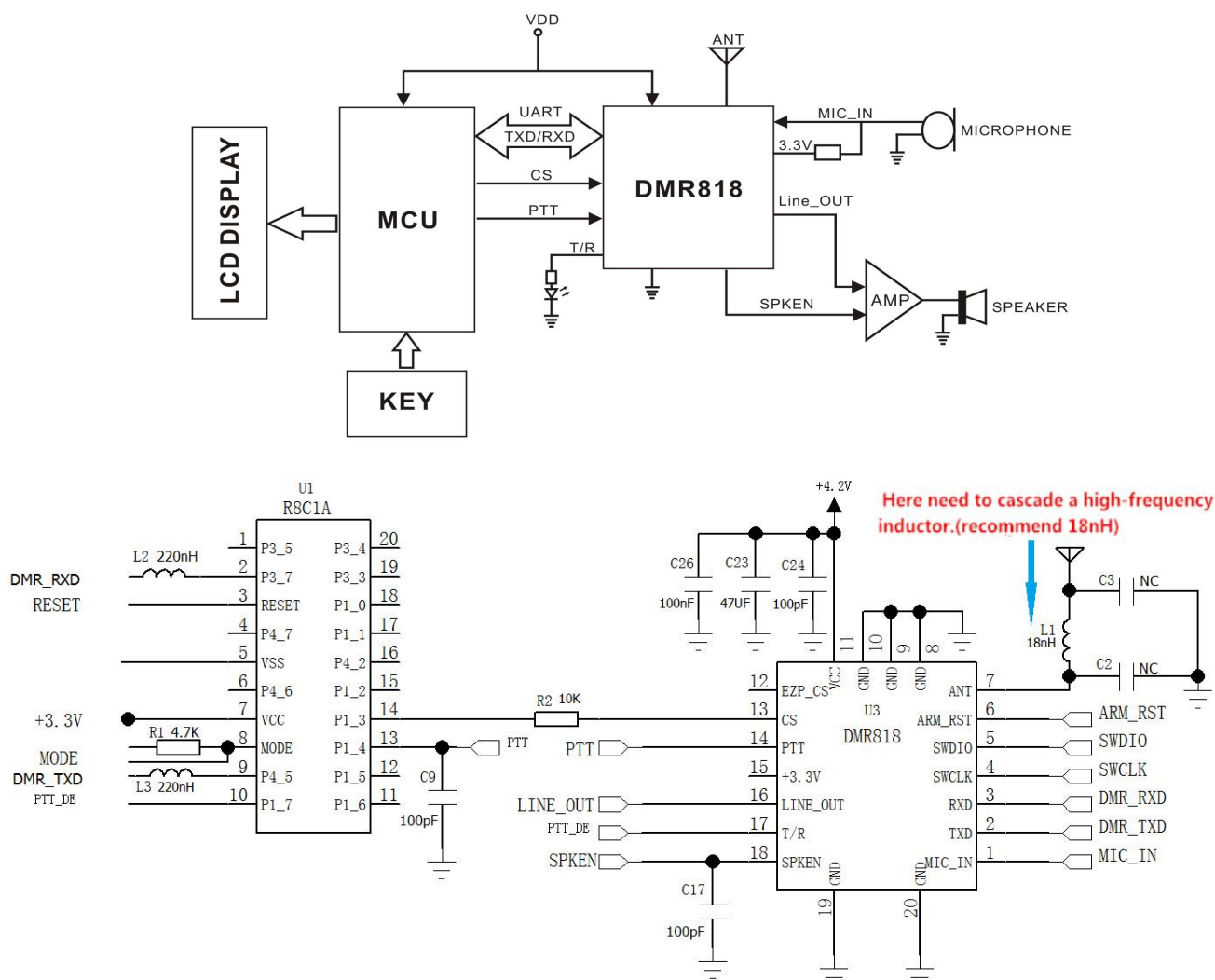

7. Functions descriptions:

DMR818 has default 16 channels, CH1~CH8 in DMR mode, CH9~CH16 in analog mode. All the parameters can be configured by serial instructions. For details, please check “ DMR818 communication protocol” .

Note: When module in radio killed mode, most of the serial instructions can't be responded, It will return message 0x07 (Radio killed) or 0x01(Busy) to indicate.

1) Voice transmission

“PTT” pin is used to control the voice transmission. Pull low to enable voice transmission; High to end transmission.

Timing operation:

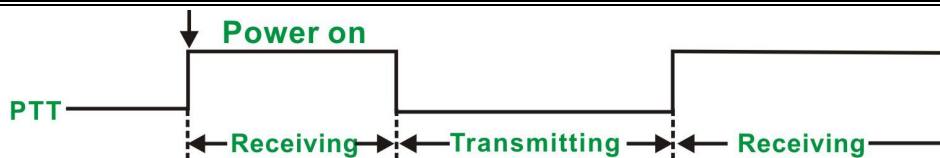

Note: Serial instructions can also be used to enable voice transmission and ending. For details, please check “DMR818 communication protocol”

2) Voice receiving

After power on, DMR818 will enter into receiving mode automatically. It will return back to receiving mode after voice transmission ended.

For details of receiving process, please check “DMR818 communication protocol”.

3) Messaging

Message can be set as confirmation message and non-confirmation message before transmission. When the message is set as non-confirmation, the message can be rejected or accepted by the receiver. When the message is confirmation, it will be accepted by user. Pre-written message can be stored and used.

For details of messages, please check “DMR818 communication protocol” .

4) Switch of Audio amplifier

Pin “SPK_EN” is used to control external audio amplifier. When playing voice, SPK_EN in high level, low level when other status. The timing of SPK_EN as blow:



8. Brief of Serial Communication Protocol

All the parameters of DMR818 can be configured using Serial Communication Protocol.

MSB for the command.

Format as below:

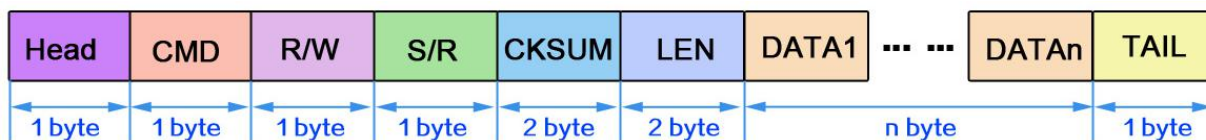

The definition of protocol as below:

Offset	Flag	Length	Comment	Detail
--------	------	--------	---------	--------

0	Head	1	Packet header	0x68
1	CMD	1	command	0x01~0x28: parameter function refer to table 1
2	R/W	1	Read /write operation	0x00: reading ; 0x01: writing ; (external CPU TX is writing, external CPU RX is reading) 0x02: initiative sending
3	S/R	1	Setting/Responding	setting: 0x01: start answering: 0x00 Done 0x01 busy or fail (note 2) 0x02 No channel or channel errors (note 3) 0x07 module killed 0x09 check error note: message, voice refer to below corresponding specification
4、5	CKSUM	2	Checksum	Checksum for all the packet
6、7	LEN	2	Data length	DATA length, no information, LEN is 0
8	DATA	len	Data info	
	TAIL	1	Tail of packet	0x10

Note 1: CMD as below:

CMD	Function	Message available for All channels or current channel	Message save when Power off (yes / no)
0x01	Channel change		yes
0x02	Receive volume	All	yes
0x03	scanning	current channel	no
0x04	Transceiver status checking	current channel	no
0x05	Signal strength value	current channel	no
0x06	Various call modes (Call Type)	current channel	no

0x07	Message mode setting and transmit	current channel	no
0x09	Emergency alarm	current channel	no
0x0a	Enhancements	current channel	no
0x0b	Mic Gain configuration	All	yes
0x0c	Power-saving mode configuration	All	yes
0x0d	Transceiver frequency	current channel	yes
0x0e	Repeater/off-web	current channel	no
0x10	Receive/call type, number output	current channel	no
0x11	Read received data	current channel	no
0x12	SQ setting	current channel	yes
0x13	Mode of CTCSS/CDCSS	current channel	yes
0x14	CTCSS/CDCSS	current channel	yes
0x15	Monitor switch	current channel	no
0x16	Bit Error rates		no
0x17	High/low power	current channel	yes
0x18	Contact person	current channel	no
0x19	Encryption switch	current channel	no
0x1a	Completed initialization		no
0x22	Transmit contacts information	current channel	no
0x23	Testing message	current channel	no
0x24	ID reading	all	no
0x25	Firmware Version reading	all	no
0x26	Check contacts list	all	no
0x27	Checking scan status	current channel	no
0x28	Checking encryption status	current channel	no

Note 2: When DMR818 is transmitting, receiving, and configuring, it will show 0x01 to tell setting fail for busy.

Note 3: It show 0x02 for below condition:

3.1: When change to non-exist channel;

3.2: It all happen when configure DMR settings in analogy channel(such as: message, special functions),

3.3 : Configure analog parameters in DMR channel.

9. Pin Assignment

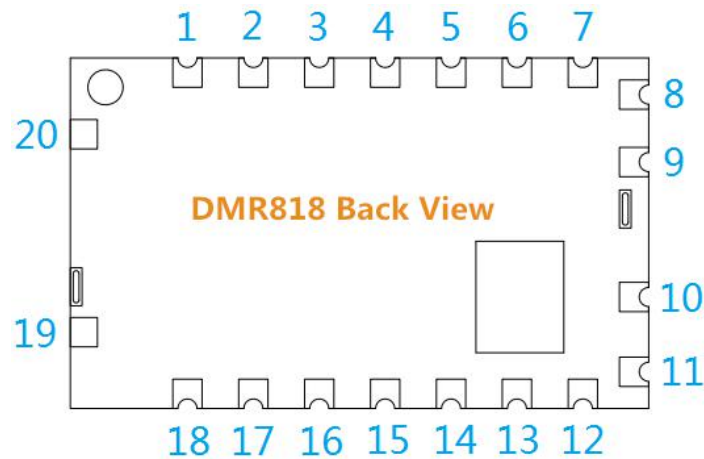

Pin NO.	Pin name	Description
1	MIC_IN	Microphone or line in
2	UART-TX	Transmit
3	UART-RX	receive
4	SWCLK	Reserved
5	SWDIO	Reserved
6	ARM_RST	Reserved
7	ANT	connect 50 ohm antenna
8	GND	Ground
9	GND	Ground
10	GND	Ground
11	VCC	External and Positive supply 3.3~5V
12	EZP_CS	Reserved for program Burning
13	CS	Leave Open or high level for normal working, pull low to enter sleeping mode
14	PTT	Module Input, Transmitting/receiving control, pull low to force the module to enter TX state; pull high for Rx state
15	+3.3V	3.3V output, connect to 50mA

16	LINE_OUT	Audio output
17	T/R	Module Output, status of Transmitting/receiving, High for TX and low for Rx
18	SPKEN	Audio amplifier control
19	GND	Ground
20	GND	Ground

10. Accessories

1) Antenna

The antenna is very important for RF communication, Its performance will affect the communication, the module requires the antenna with 50Ω impedance. Universal antennas are Rod antenna, sucker antenna and telescopic antenna, User can choose the right antenna according to their application. We advise to use antennas listed on our website to get better performance.

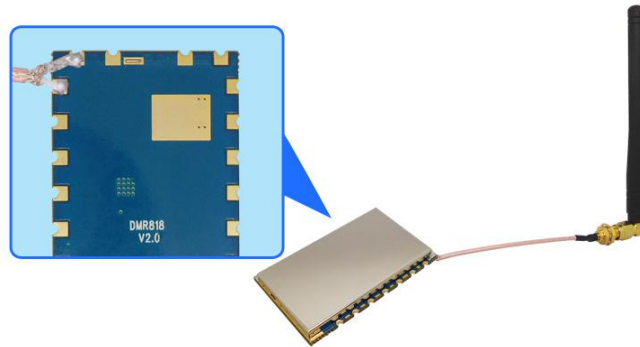

11. Mechanism Dimension(Unit:mm)

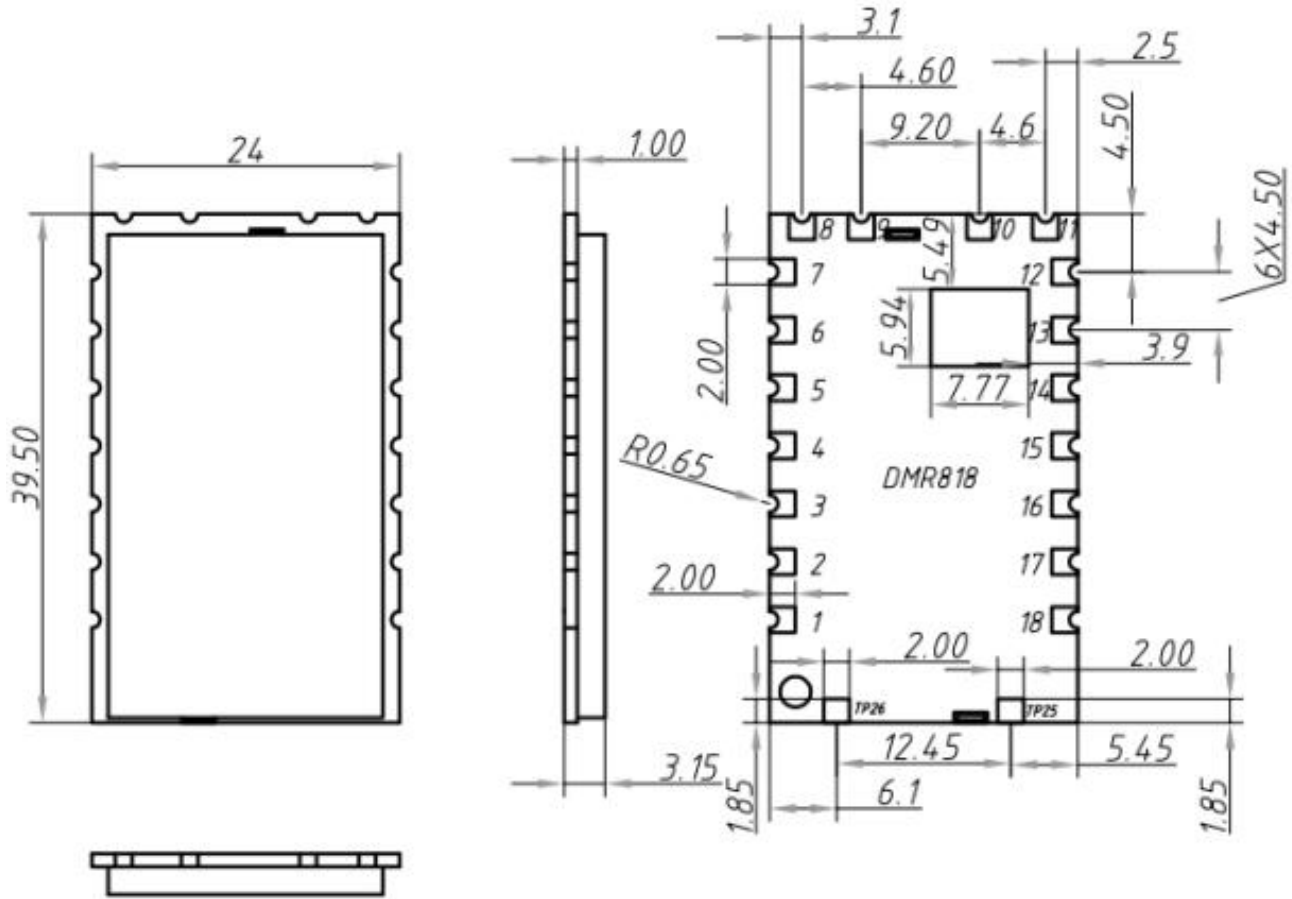

Appendix: SMD Reflow Chart

We recommend you should obey the IPC related standards in setting the reflow profile:

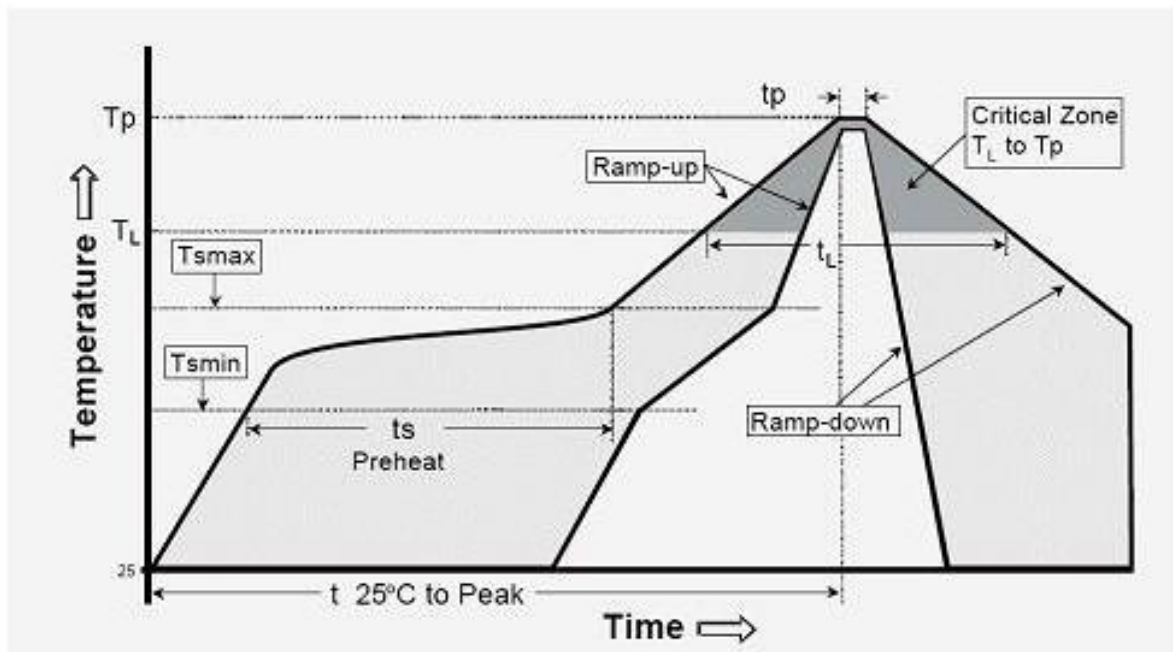

IPC/JEDEC J-STD-020B the condition for lead-free reflow soldering	big size components (thickness $\geq 2.5\text{mm}$)
The ramp-up rate (Tl to Tp)	3°C/s (max.)
preheat temperature	
- Temperature minimum (Tsmmin)	150°C
- Temperature maximum (Tsmmax)	200°C
- preheat time (ts)	60~180s
Average ramp-up rate(Tsmmax to Tp)	3°C/s (Max.)
- Liquidous temperature(TL)	217°C
- Time at liquidous(tL)	60~150 second
peak temperature(Tp)	245+/-5°C